

# ROLL-OFF BIN SCALES



ROLL-OFF BIN SCALE



# ROLL-OFF BIN SCALES

## Load Cell Assembly

The standard Tuff-Deck utilizes a self restoring Rocker Pin design load cell, 30 tonne capacity each, with 150% safe working overload, and 350% ultimate overload capability.

This load cell is manufactured from 17-4 PH and 316 stainless steel materials and is highly resistant to corrosion. The latest manufacturing technologies are utilized in its manufacture including laser welding. The load cells have factory matched outputs, requiring minimal field adjustments on initial and subsequent calibrations. The Rocker Pin is purged and filled with inert gas, hermetically sealed to IP68 (submersion at 1 metre for 100 hours) and IP69K (high pressure steam jet) standards, is NTEP approved Class III L 10,000 d and OIML approved to R60 specifications.

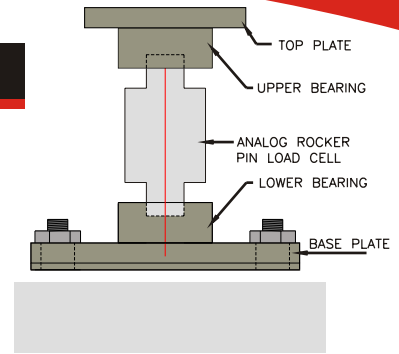

The signal cable from the load cells has internal braided shield to protect from R.F.I. There is a heavy duty external braid to provide mechanical protection from abrasion damage and chewing rodents.

The rocker pin load cell allows a simple mounting arrangement with one lower and one upper bearing. The load cell is supplied with a rubber boot to protect the lower bearing from mud contamination. There are no links or pins to wear out. The mount allows for high impact loading typical of highway vehicles and includes anti-rotation hardware. The rocker pin assembly compensates for thermal expansion of the weighbridge tolerating up to 5 degrees off-center loading.

Polycarbonate NEMA 4-X corrosion proof summation boxes with captive gasket system are mounted on the side of the scale to protect against moisture and condensation entry into the load cell signal summing system and includes a patented water proof vent system to prevent condensation forming in the summing boxes.

The Active Scale summing system is available with an optional remote section trimming kit located in the scale house allowing simple, fast initial and routine calibrations. The location of the remote calibration assembly in a controlled environment promotes the stability and accuracy of your scale and also provides faster calibration.

## Accessories

A complete line of accessories is available from digital weight indicators, printers and remote displays to bar code systems, computerized scale house ticketing systems and unattended weigh stations.

## Weigh-Deck Options

- Self Contained with Sub Frame
- Custom Paint Systems
- Galvanizing
- End Stops

## Sizes and Capacities

- Widths  
One width. Bin receiver emulates truck bed.
- Lengths  
Standard module lengths are 16' to 28'.
- Capacities  
Standard scale capacity is 50 tonnes.

### Head Office & Plant

6 York Road  
Brantford, ON, N3T 5Y6  
Email: [info@activescale.com](mailto:info@activescale.com)

Toll Free: 1-866-284-2223  
Fax: 519-756-0267  
24 Hour Service: 1-800-850-8770

Products are available through Active Scale Sales Offices, or through dealers located across Canada and the United States Specifications are subject to changes without prior notice